

High sensitivity color camera

## KP-DE500

High sensitivity black and white camera

## KP-E500



### High sensitivity color camera KP-DE500

#### 100 Times More Sensitive Than A Normal Camera

- A new 1/2 inch EM-CCD with electron multiplication is used to achieve exceptional sensitivity.

Color in full motion mode	0.009 lx
Color accumulation mode	0.00015 lx
Monochrome in full motion mode	0.0005 lx
Monochrome accumulation mode	0.000008 lx

#### Hitachi Technology Enables Superior Image Reproduction In Low Light Levels

- Thermoelectric cooling used on the EM-CCD to reduce the effects of dark current noise along with a new digital signal processor (DSP) that provides digital noise reduction of the luminous signal yields sharp clear pictures with a high S/N ratio.

### High sensitivity monochrome camera KP-E500

#### For Even Greater Sensitivity A Monochrome Version of the Camera is Available Allowing Use in Even Lower Light Levels

- In the normal mode of operation the camera provides higher sensitivity as compared to a normal camera. In the accumulation mode unmatched sensitivity is achieved allowing use in extremely low light situations.

Monochrome in full motion mode	0.0003 lx
Monochrome accumulation mode	0.000005 lx

#### Electron Multiplication used in the EM-CCD Improves Performance While Reducing Technical Issues

- Typical high sensitivity cameras use an Image Intensifier Tube that is subject to burn in, afterimage (lag) and short life span. These problems are eliminated with the use of the EM-CCD.



## Main Specifications

<b>Pickup element</b>	1/2-inch interline EM-CCD
<b>Total pixels</b>	680(H) x 500(V)
<b>Effective pixels</b>	658(H) x 496(V)
<b>Imaging area</b>	6.58(H) x 4.96(V) mm
<b>Pixel pitch</b>	10.0(H) x 10.0(V) $\mu$ m (Square pixel)
<b>Scanning system</b>	2 : 1 Interlace
<b>Scanning frequency</b>	Horizontal 15.734 kHz      Vertical 59.94 Hz
<b>Synchronization</b>	Internal
<b>Video output</b>	
<b>VBS output</b>	Video 0.7 Vp-p Plus terminal nature
<b>Sync</b>	0.3 Vp-p Negative polarity
<b>Burst</b>	0.3 Vp-p, More than 8 cycles
<b>Impedance</b>	75 $\Omega$ Un-balancing.
<b>Signal-processing system</b>	Digital processing (Input 10 bit)
<b>Signal to noise ratio (S/N)</b>	50 dB or more (luminosity signal, Gamma OFF, minimum gain, without detail boost)
<b>Resolution</b>	Horizontal: 480 lines      Vertical: 350 lines (In the central part)
<b>Minimum photographic subject illumination KP-DE500</b>	0.009 lx (Color in full motion, maximum sensitivity setup, F1.4, 50 IRE) 0.005 lx (Monochrome in full motion, maximum sensitivity setup, F1.4, 50 IRE) 0.00015 lx (Color 64 time accumulation, maximum sensitivity setup, F1.4, 50 IRE) 0.000008 lx (Monochrome 64 time accumulation, maximum sensitivity setup, F1.4, 50 IRE)
<b>Minimum photographic subject illumination KP-E500</b>	0.0003 lx (Monochrome in full motion, maximum sensitivity setup, F1.4, 50 IRE) 0.000005 lx (Monochrome 64 time accumulation, maximum sensitivity setup, F1.4, 50 IRE)
<b>Sensitivity (Gain) setup</b>	Auto or a manual (factory set-AUTO)
<b>Electronic shutter</b>	Shutter: 7 steps /AES (factory set-OFF) OFF(1/60), 1/100, 1/125, 1/250, 1/500, 1/1000, 1/2000 sec
<b>Accumulation magnification setup</b>	Auto or a fixed change is possible. (factory set-AUTO) 2, 4, 6, 8, 10, 16, 32, 64 times
<b>Backlight compensation</b>	An ON/OFF change is possible (factory set-OFF) Light-measurement area: Nine area to selection is possible.

<b>The output for auto iris lenses</b>	(Square shape 4 pin, JEITA conformity) A galvanometer system/video signal
<b>White balance control</b>	From the following three modes to selection (factory set-ATW) *Only KP-DE500 (color) ATW: The mode which follows automatically AWC: The mode which holds a white balance after an automatic setup MANUAL: They are red and the mode which carries out blue gain adjustment and unites a white with manual operation
<b>Camera title character display</b>	A display is possible to 22 characters in an alphanumeric character and a sign A setup to either of two upper and lower sides of a screen is possible in the position of a character.
<b>B/W Mode</b>	OFF: The mode of fixation on a color image
<b>*Only KP-DE500 (color)</b>	On: In high sensitivity black image mode AUTO: With luminous intensity OFF of high sensitivity black image, the mode where ON changes automatically In addition, it changes, as for luminous intensity from 3 stages of the HI, the MID and the LOW selective possibility
<b>Picture quality adjustment menu</b>	Following to the menu indication of the picture, various picture quality adjustments and mode selection are possible
<b>DNR</b>	Change of AUTO / MANU (8 steps) (factory set-AUTO)
<b>Power supply voltage</b>	DC 12V $\pm$ 1 V
<b>Current consumption</b>	Approximately 1.5 A (excluding lens load)
<b>Lens mount</b>	The C / CS mount (flange back adjustment mechanism it is attached)
<b>Ambient, operating</b>	- 10 $^{\circ}$ C - + 50 $^{\circ}$ C / 30 - 80% RH *when in order for you to use with the efficiency which long time is stabilized, it continues uses by all means +40 $^{\circ}$ C please use at below.
<b>Ambient, storage</b>	Retention: 20 $^{\circ}$ C - + 60 $^{\circ}$ C / 20 - 90% RH
<b>Vibration endurance</b>	24.5 m/s <sup>2</sup> (10 - 200Hz XYZ direction each 30 minute) *Please do not add the strong vibration over long time.
<b>External dimensions</b>	78(W) x 63(H) x 170(D) mm (The lens and the projection section are excluded)
<b>Mass</b>	Approximately 53g (The lens is excluded)

## Dimensions

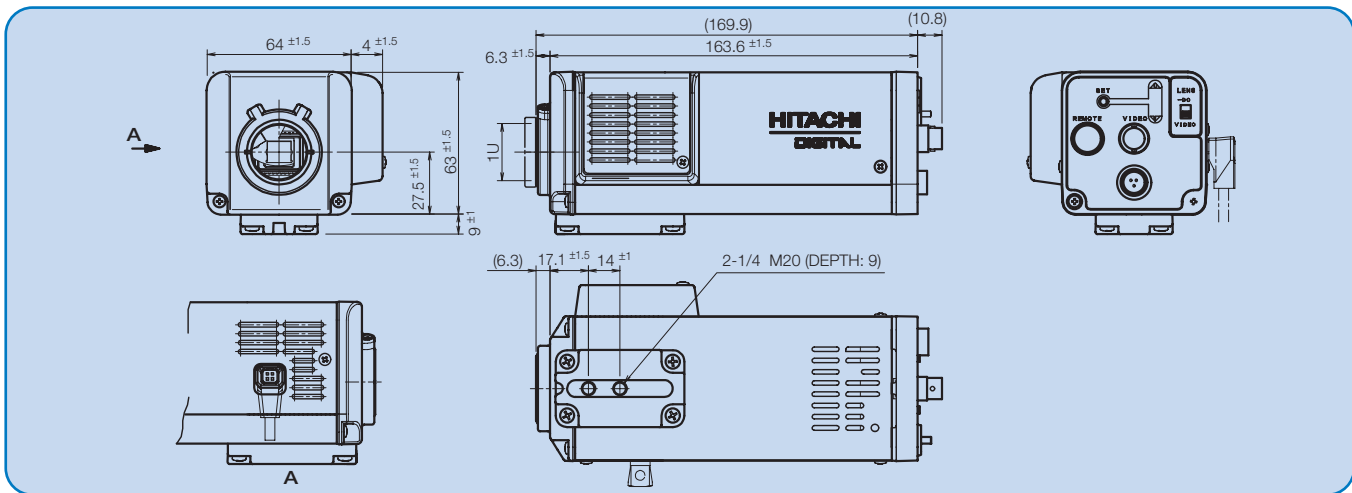

**CAUTION:** To ensure safe operation, please read the instruction manual before using this product.

These Specifications are subject to change without notice.

## Hitachi Kokusai Electric Inc.

**Head Office** : 14-20, Higashi-Nakano 3-choume, Nakano-ku, Tokyo 164-8511, Japan  
Phone : +81(0) 3-3368-6111, Fax : +81(0) 3-3365-9119  
URL : <http://www.h-kokusai.com>

**Beijing Office**  
Beijing Fortune Building 5, Dong San Huan Bei-lu, Chao Yang District, Beijing, 100029 China  
Phone : +86(0) 10-6590-8755/8756, Fax : +86(0) 10-6590-8757

**Hitachi Denshi America, Ltd.** URL : <http://www.hitachidenshi.com>  
**Headquarters and Northeast Office** : 150 Crossways Park Drive, Woodbury, New York 11797, U. S. A.  
Phone : (+1) 516-921-7200, Fax : (+1) 516-496-3718

**West Office** : 371 Van Ness Way, Suite 120 Torrance, CA, 90501, U. S. A.  
Phone : (+1) 310-328-6116, Fax : (+1) 310-328-6252

**Midwest Sales** : Phone : (+1) 330-334-4115, Fax : (+1) 516-496-3718  
Service (+1) 989-345-5379

**South Sales** : Service (+1) 256-774-3777  
**Paris Center** : Phone : (+1) 516-682-4435, Fax : (+1) 516-921-0993  
**Latin Sales** : Phone : (+1) 516-682-4420, Fax : (+1) 516-496-3718

**Hitachi Denshi Canada, Ltd.** URL : <http://www.hitachidenshi.ca>  
**Head Office** : 1 Select Avenue Unit#12 Scarborough, Ontario M1V 5J3, Canada  
Phone : (+1) 416-299-5900, Fax : (+1) 416-299-0450

**Eastern Office** : 5795 Chemin St. Francois St. Laurent, Quebec H4S 1B6, Canada  
Phone : (+1) 514-332-6887, Fax : (+1) 514-335-1664

## Hitachi Denshi (Europa) GmbH

**Head Office** : Weiskircher Straße 88, Jügesheim D-63110 Rodgau, Germany  
Phone : +49(0) 6106-69920, Fax : +49(0) 6106-16906  
URL : [www.hitachi-service.net](http://www.hitachi-service.net)  
General email address : [webmaster@hitachi-denshi.de](mailto:webmaster@hitachi-denshi.de)

## Hitachi Denshi (U. K.) Ltd.

**Head Office** : Windsor House, Britannia Road, Waltham Cross, Hertfordshire EN8 7NX, United Kingdom  
Phone : +44(0) 845-121-2177, Fax : +44(0) 845-121-2180  
**Leeds Office** : Brookfield House, Selby Road, Garforth, Leeds LS25 1NB, United Kingdom  
Phone : +44(0) 113-287-4400, Fax : +44(0) 113-287-4260  
URL : [www.hitachi-denshi-uk.com](http://www.hitachi-denshi-uk.com)  
General email address : [sales@hitachi-denshi-uk.com](mailto:sales@hitachi-denshi-uk.com)



**CERTIFICATE No.**  
JMI-0062  
ISO 9001/BS 5750Pt1  
EN 29001/JIS Z9901