

These products are manufactured at a factory which has received quality control system certification in accordance with the ISO international standards.



CERTIFICATE No.  
**JMI-0062**  
ISO 9001/BS 5750Pt1  
EN 29001/JIS Z9901

# HITACHI

## KP-D28 1/3-inch CCD

## KP-D591 1/2-inch CCD

High Sensitivity Single Chip  
Digital Signal Processing Color Camera

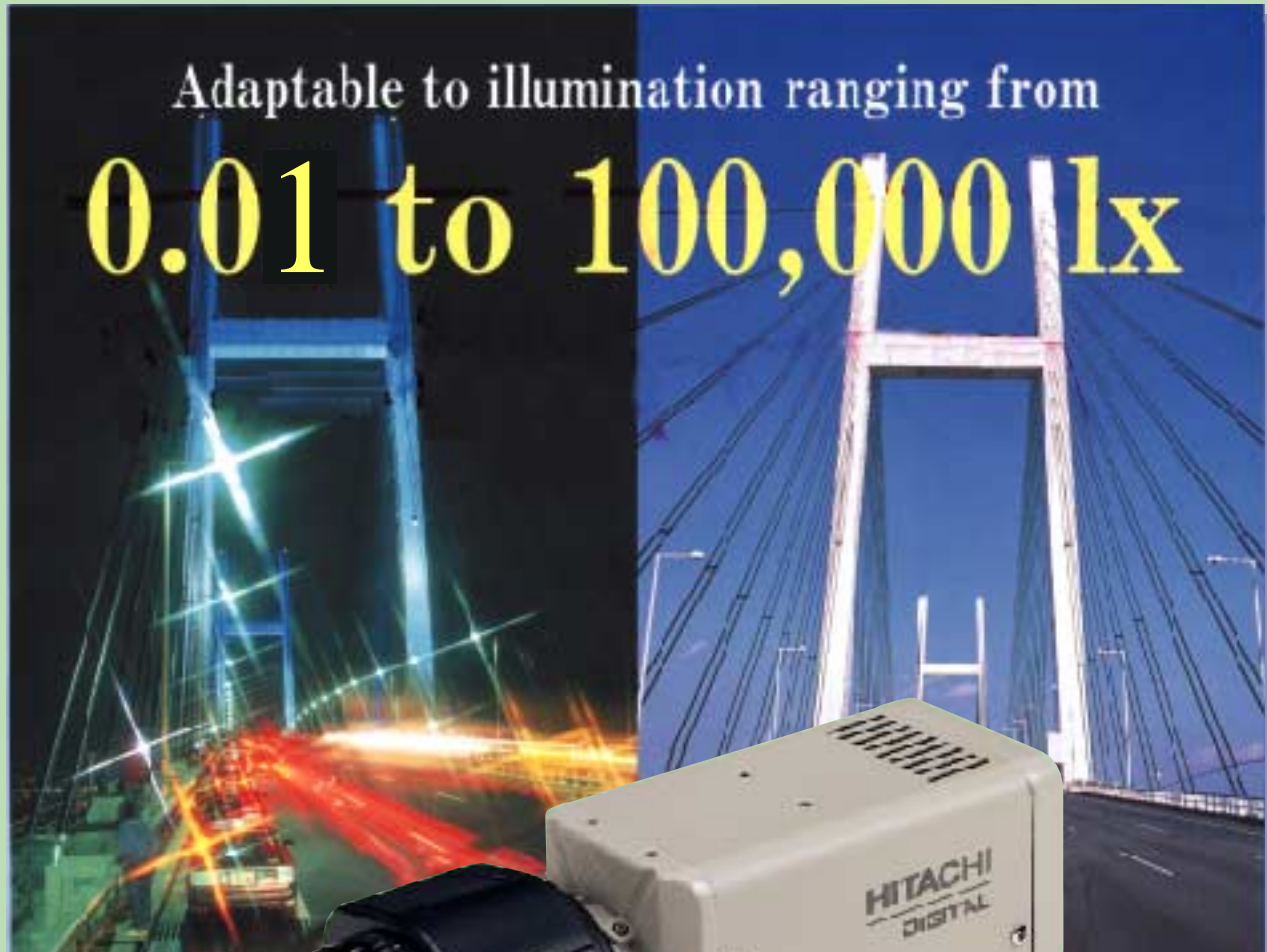

Adaptable to illumination ranging from

# 0.01 to 100,000 lx

# DIGITAL

A large, blue, 3D-style word 'DIGITAL' with a green-to-yellow gradient shadow underneath it, creating a sense of depth and reflection on the light green background.

# ULTRA SLOW MOTION



Highway



Fluorescence Microscope



Air Port



Power Plant

- Integration system using the CCD exposure time control system and a field memory to provide continuous video output.
- Digital Signal Processing system featuring various correction and control features for the video signal in the digital domain.
- High density 410,000 pixel microlens CCD.

Thanks to the above features, a high sensitivity and high resolution camera is realized, and a sharp, clear picture is ensured even under low illumination.

The KP-D591 is most suitable for a wide range of applications. Because the KP-D591 is provided with various functions including the picture expansion function by electronic zoom, auto white balance, ES lens output, genlock and sensitivity setting.

## Features

### ● High Sensitivity and High Resolution

Sensitivity can be increased approximately 64 times compared to standard sensitivity by the long exposure function of the charge integration on the CCD image sensor. A sharp, clear picture can be obtained at night.

With the auto exposure control mode established, the KP-D591 can be used continuously for day and night operation without operator intervention.

The minimum illumination in the maximum exposure mode is 0.01 lx using a f1.2 lens with the AGC set to 31dB of gain. A thermoelectric cooling device is attached to the CCD so the affects dark current noise and blemishes are not visible even in the long exposure mode.

The horizontal resolution of 480 TV lines (470TVL PAL) is realized by using a high density inter-line CCD with micro lenses.

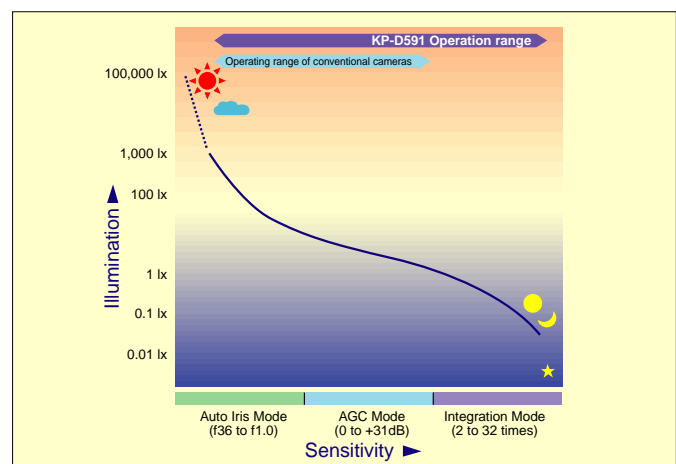



## Features

### ● Digital Signal Processor

Digital Signal Processing is used in the 2H enhancer and the contour corrector to produce a sharp, clear picture with a high signal-to-noise ratio. Further, optimum picture quality can be achieved under a wide variety of conditions, by selecting among the various control function items from the on-screen menu system.

### ● Backlight Correction

The backlight correction function is available for auto iris lenses using a video signal or a DC signal as the control voltage. When a strong light source or reflection exists in a scene, the auto iris signal controlling the lens is adjusted to a lower level, resulting in a dark unclear picture. To correct this effect, the KP-D591 is provided with various photometric areas, allowing user selection for optimum improvement of picture quality. (Photo shows a picture improved by the use of this function.)



### ● Auto White Balance Control

Three modes of auto white balance are selectable. In the auto tracking white (ATW) balance mode, the white portion of the scene is continuously detected to activate the auto white balance function to maintain proper color balance in the color temperature range from 2500K to 10000K. In the preset (AWC) mode, white balance is adjusted, when a white object is shot and the preset mode switch is pressed. In the manual mode of white balance, red and blue gains can be adjusted manually.

### ● Text Display

Up to 24 alphanumeric characters can be displayed at the user-selected position on the screen.



### ● Remote Control (RS-232C Interface)

All menu adjustment items are available for control through the use of a personal computer.

### ● Picture Quality Adjustment Menu

An on-screen menu system in conjunction with the five function switches on the camera rear panel, allows user to configure the selection and adjustment of various operational modes and items to produce the optimum image quality.

### ● Electronic Zoom

Digital zoom allows picture to be smoothly magnified up to 4 times. Once magnified, the image can be moved vertically or horizontally.



(\*The resolution is reduced by electronics ZOOMING.)

### ● Noise reduction

Digital noise reduction can be selected to reduce the effects of repetitive noise in the long exposure mode.

### ● High Speed Electronic Shutter

An eight step electronic shutter with speeds of 1/30000, 1/20000, 1/4000, 1/2000, 1/1000, 1/500, 1/250, 1/100 (PAL 1/120) and 1/60s (PAL 1/50s) can be selected to eliminate blurring of fast moving objects. Further an AES (auto electronic shutter) mode can be selected to control the light level when using lenses with a fixed or manual iris, or to extend the effective iris range of auto iris lenses.

## Dimensions

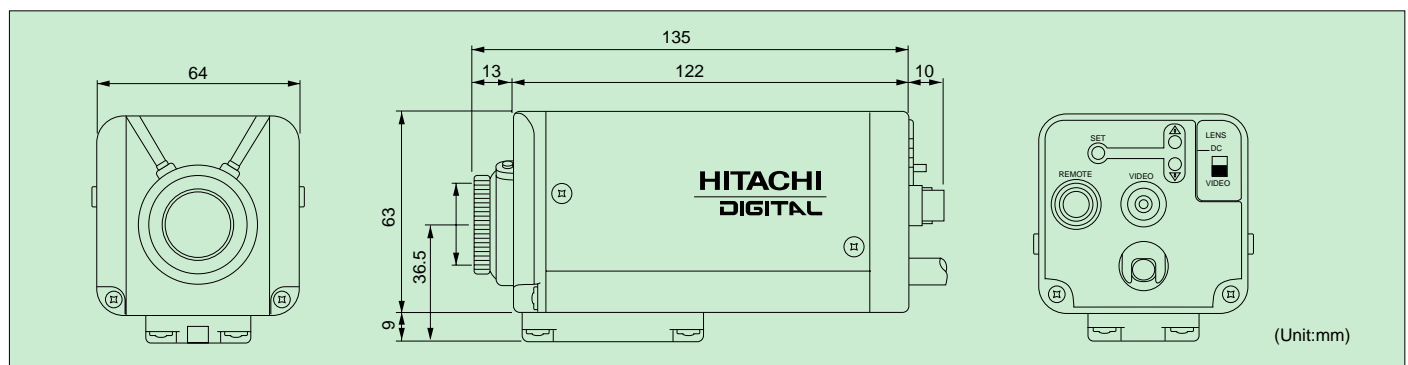

# Specifications

<b>Imaging device</b>	KP-D28:1/3 " KP-D591:1/2 "		
	Inter-line CCD with micro lens on chip		
	NTSC		PAL
Effective pixels	768 (H) x494 (V)	752 (H) x582 (V)	
Total pixels	811 (H) x508 (V)	795 (H) x595 (V)	
<b>Scanning system</b>	2:1 interlaced		
<b>Scanning frequency</b>	NTSC		PAL
Hor.	15.734 kHz	15.625 kHz	
Vert.	59.94 kHz	50 Hz	
<b>Resolution</b>	NTSC		PAL NTSC/PAL
Standard	H:480 TVL	H:470 TVL	V:350 TVL
Exposure	H:440 TYL	H:440 TVL	V:260 TVL
<b>Signal-to-noise ratio</b>	50 dB		
<b>Sensitivity</b>	Standard	Max	
	KP-D591 1.0 lx(Max AGC)	0.01 lx(AGC max. 6.4x. F1.2)	
	KP-D28 1.5 lx(Max AGC)	0.02 lx(AGC max. 6.4x. F1.2)	
<b>Illumination range</b>	KP-D591 0.01 lx to 100.000 lx(f1.2 ES lens)		
	KP-D28 0.02 lx to 100.000 lx(f1.2 ES lens)		
<b>Signal processing system</b>	Digital signal processing A/D:10-bit Processing:8-bit		
<b>Video signal output</b>	Composite video signal:1.0 Vp-p/75 ohm, unbalanced BNC connector		
<b>Sync system</b>	Internal or external(Line Lock).		
<b>AGC</b>	ON/OFF switchable		
	Max gain at ON:6,12, 21, 31 dB(Factory setting:21 dB)		
<b>Electronic shutter speed</b>	11 steps selectable		
	1/60 (PAL,1/50),1/100,1/250,1/500,1/1000,1/2000,1/4000,1/10,000,1/20,000,1/30,000,AUTO.		
<b>Backlight correction</b>	Backlight correction using 9 photometric areas.		
<b>Output for auto iris lens</b>	Video signal input type or iris control voltage input type switchable.		
	(1) Video signal input type lens mode (VIDEO) Video signal:1.0 Vp-p/high impedance Power supply:12 VDC,max.60 mA		
	(2) Iris control voltage input type (Galvanometer type) lens mode (DC) Impedance Damper:1150 ohm ±10 % Driv:190 ohm ±10 % Connector:Square type, 4-pin		
<b>Text display</b>	Up to 24 alphanumeric can be displayed and position can be set.		
<b>White balance control</b>	3 control modes selectable (1) Auto tracking (ATW)mode (2) Preset (AWC) mode (3) Manual (MANUAL)mode (R/B gain adjustment)		
<b>Sensitivity setting</b>	Automatic sensitivity (AUTO) or fixed sensitivity (MANUAL) selectable. Maximum sensitivity can be set in AUTO mode. Standard sensitivity (NTSC:1/60 s, PAL:1/50 s) or 2 to 64 times.		

<b>Electronic zoom</b>	Max. magnification:4 times
<b>Picture quality adjustment menu</b>	Adjustment of each item and selection of each mode can be made, using menu screens. (1) Text display ON/OFF, text editable, display position settable (TOP or BOTTOM). (2)Level detection area selectable (3)Iris level adjustable (4)AGC ON/OFF (5)White balance (6)Shutter speed (7)Gamma correction ON/OFF (8)Video signal polarity selectable (9)Chroma level adjustable (10)Black level adjustable (11)Contour correction amount adjustable (12)Exposure time setting AUTO/MANUAL Max. exposure time can be set, up to 2 to 64 times in step by fields in AUTO mode. (13)Electronic zoom Zoom ratio: Nomal to 4 times (Adjustable).
<b>Lens mount</b>	C/CS mount (C-mount adaptor)
<b>Camera mount</b>	Bottom: 1/4 ", 20UNC With supplied tripod adaptor TA-231 needed
<b>Operating conditions</b>	-10 to +50 °C, 30 to 80 %RH
<b>Storage conditions</b>	-20 to +60 °C, 20 to 90 %RH
<b>Anti-vibration</b>	3G or less
<b>Power supply</b>	U: 117 VAC ±10 %, 60 Hz, E/K:230 VAC ±10 %, 50 Hz
<b>Power consumption</b>	KP-D591 U 6 W KP-D591 E/K 7 W KP-D28 U 4.5 W KP-D28 E/K 5.5 W
<b>Dimensions</b>	64 (W)x63 (H)x122 (D)mm (Excl. lens and protrusions)
<b>Mass</b>	KP-D591U 740 g KP-D591E 750 g KP-D591K 700 g KP-D28U 730 g KP-D28E 740 g KP-D28K 690 g
<b>Composition</b>	Camera KP-D591/KP-D28 Operation manual x1 Fuse x1 C-mount adaptor x1 Lens plug(E4-191J-100)
<b>Optional accessories</b>	Lenses Remote plug, HR10A-10P-12P(01)

DNR: Digital Noise Reducer

●The Specification are subject to change without notice for improvement.

## Hitachi Kokusai Electric Inc.

Head Office : 14-20,Higashi-Nakano 3-choume, Nakano-ku, Tokyo 164-8511, Japan  
Phone : (03) 3368-6111, Fax : (03) 3365-9119

### International Operation's Division

1, Kanda izumi-cho Chiyoda-ku Tokyo 101-0024, Japan  
Phone : (03)5821-5311, Fax : (03) 5821-5394

### Beijing Office

Beijing Fortune Building 5, Dong San Huan Bei-lu, Chao Yang District, Beijing, 100029 China  
Phone : (10) 6590-8758/8756, Fax : (10) 6590-8757

### Hitachi Denshi America, Ltd.

Headquarters and : 150 Crossways Park Drive, Woodbury, New York 11797, U. S. A.  
Northeast Office : Phone : (516) 921-7200, Fax : (516) 496-3718

West Office : 371 Van Ness Way, Suite 120 Torrance, CA, 90501, U. S. A.  
Phone : (310) 328-6116, Fax : (310) 328-6252

Midwest Sales : Phone : (877) 326-8104, Fax : (516) 496-3718  
Service (734) 721-6180

South Sales : Phone : (877) 326-8105, Fax : (516) 496-3718  
Service (618) 937-0201

Parts Center : Phone : (516) 682-4435, Fax : (516) 921-0993

Latin Sales : Phone : (516) 682-4420, Fax : (516) 496-3718

### Hitachi Denshi Canada, Ltd.

Head Office : 1 Select Avenue, Unit#14 Scarborough, Ontario M1V 5J3, Canada.  
Phone : (416) 299-5900, Fax : (416) 299-0450

Eastern Office : 5795 Chemin St. Francois St. Laurent, Quebec H4S 1B6, Canada  
Phone : (514) 332-6687, Fax : (514) 335-1664

Ottawa Office : 9 Antares Drive, Nepean, Ontario, K2E 7V5, Canada  
Phone : (613) 727-3930, Fax : (613) 825-4253

### Hitachi Denshi (Europa) GmbH

Head Office : Weskircher Straße 88, Jügesheim D-63110 Rodgau, Germany  
Phone : (6106) 6992-0, Fax : (6106) 1690-6

### Hitachi Denshi (U. K.) Ltd.

Head Office : 14 Garrick Industrial Centre, Irving Way, Hendon, London, NW9 6AQ, United Kingdom  
Phone : (181) 202-4311, Fax : (181) 202-2451

Leeds Office : Brookfield House, Selby Road, Garforth, Leeds LS25 1NB United Kingdom  
Phone : (113) 287-4400, Fax : (113) 287-4266