

X64-AN Quad™

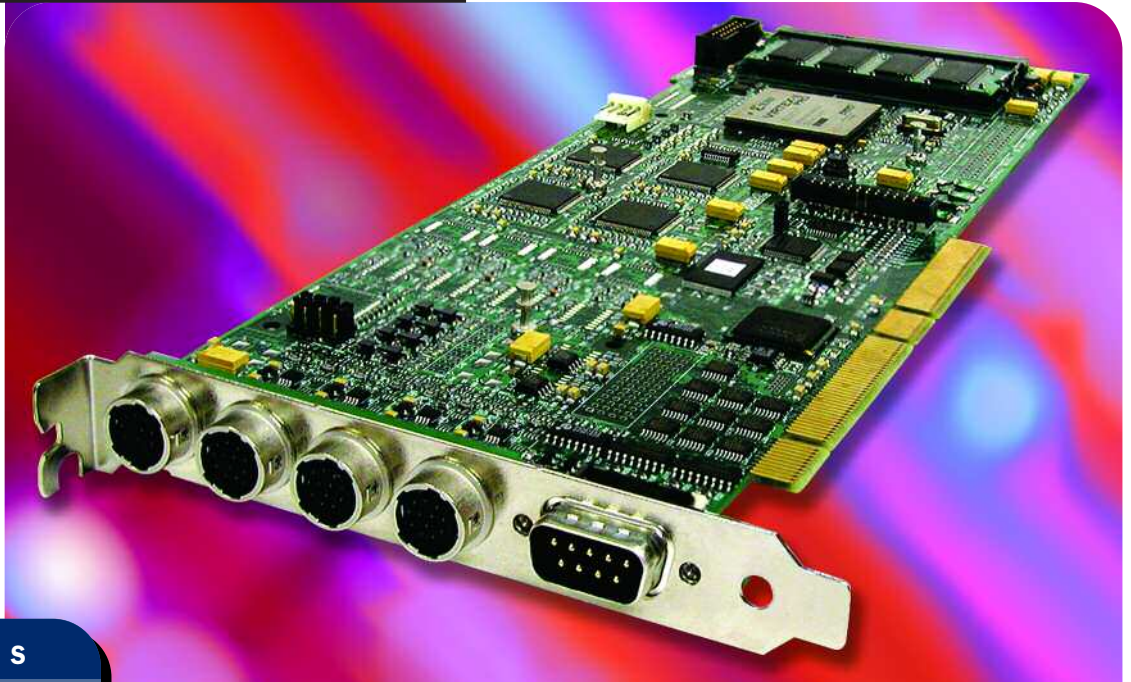

KEY FEATURES

- Image time stamp for accurate object tracking of each input channel
- Concurrent acquisition from up to four independent format cameras
- High-speed image transfers at up to 528MB/s
- PCI-X 66MHz compatible
- Supports Windows® XP, 2000 and NT

OVERVIEW

64-Bit Multi-Channel Analog frame grabber

The X64-AN Quad is a high-performance PCI-X bus compatible frame grabber. Driven by the need to integrate vision automation with multiple view inspection, the X64-AN Quad is designed to deliver concurrent image acquisition from multiple independent standard and progressive scan analog cameras.

The X64-AN Quad is capable of grabbing from four independent cameras at the same time, and offers independent control signals for each input channel to acquire, transfer and track images accurately. Supporting high-resolution 8-bit image digitization, the X64-AN Quad offers independent image paths creating virtually four frame grabbers in one slot.

The X64-AN Quad has been built within Coreco Imaging's Trigger-to-Image Reliability technology framework. High-speed in-line machine vision applications require tight integration between the trigger, strobe, camera exposure and frame grabber acquisition to ensure data integrity. Trigger-to-Image Reliability leverages Coreco Imaging's hardware and software innovations to control, monitor and correct the image acquisition process from the time that an external trigger event occurs to the moment the data is sent to the PCI bus, providing traceability when errors do occur and permitting recovery from those errors.

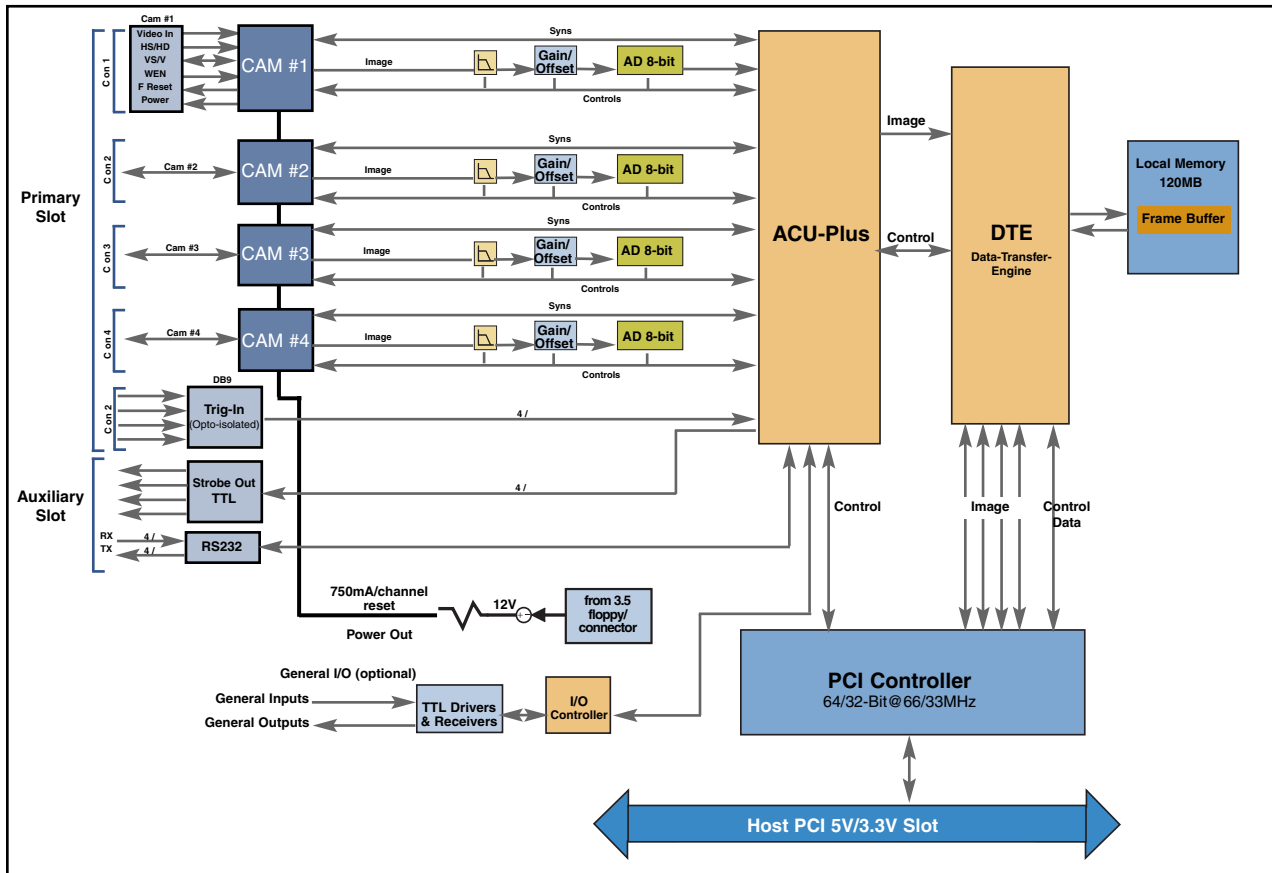

X64-AN Quad - Functional Block Diagram

Unprecedented Acquisition Control

Successful industrial machine vision applications require consistent and predictable results in demanding operating environments. With all image acquisition functions integrated on a single board and under a single API, the X64-AN Quad ensures highly reliable acquisition control throughout the entire image capture sequence – from the time a trigger is fired to the time an image is available in host memory. Embedded timing logic within the board's Acquisition Control Unit (ACU) provides timing signals to drive HD and VD for each input channel. A dedicated timer/counter for each module also ensures that the acquired images are tracked reliably throughout the data path allowing image data to be readily correlated with physical objects on the production line.

Capable of acquiring images at rates up to 50MB/s per input path, the X64-AN Quad makes image acquisition from the new generation of analog cameras more efficient and supports operating modes such as asynchronous reset, E-donpisha, partial scan, and WEN.

Improved Anti-Aliasing Filter

For improved image quality and accuracy, the X64-AN Quad offers an optional fifth order Butterworth anti-aliasing filter to remove unwanted noise from the video signal; separate gain and offset controls for each video input span the entire 0.4 to 1.2V range in steps of 780µV. These precise and flexible controls give operators

the ability to adapt input video signals to deliver digitized images that are highly linear and have low jitter noise.

Camera Support

The X64-AN Quad performs acquisitions from up to four independent format analog cameras with a comprehensive suite of independent control signals such as master mode synchronization, WEN, frame reset, trigger, and strobe outputs. The X64-AN Quad comes bundled with CamExpert™ a proprietary camera configuration utility specifically designed to leverage the power of Coreco Imaging's image acquisition boards. This Windows-based utility provides an interactive environment within which to create a new, or modify an existing, configuration file for both standard and progressive scan cameras.

Visual Status LED

The X64-AN Quad features visual status LEDs to simplify system setup and diagnostics. A status indicator LED provides visual feedback once the camera connection is made and properly synchronized. These visual indicators greatly facilitate the diagnostic process by allowing developers to instantly recognize if cabling has been correctly set up.

Optimized Data Transfer

Delivering fast and secure data transfer with zero CPU usage, the Data Transfer Engine (DTE) features a high-speed memory interface, multiple independent Direct Memory Access (DMA), and onboard tap descriptors, the DTE's powerful architecture delivers robust performance for critical machine vision tasks.

The DMAs allow the DTE to transfer images from the ACU to local frame buffer memory, or transfer the same image to multiple addresses in the host memory. The ACU and DTE use the onboard 128MB memory to perform these operations concurrently, yet at different rates, yielding optimal utilization of system bandwidth.

Conventional PCI bus transfers, utilizing scatter-gather techniques, rely on the CPU to load the host frame buffer destination memory addresses during live acquisition, which increases the load on the CPU and slows image-processing tasks. The DTE offloads this task by automatically capturing and storing the destination frame buffer addresses from the host memory. In addition, it performs autonomous and robust image transfers in non-real-time operating systems, such as Windows XP, Windows 2000 and Windows NT®.

General Purpose I/Os

An optional module offers opto-coupled inputs and outputs for demanding industrial environments. These interrupt-driven, general-purpose input and output controls allow X64-AN Quad boards to react to external inputs more rapidly and predictably increasing the quality of acquired images.

External Event Synchronization

To synchronize image captures with external events the X64-AN Quad features an optically isolated trigger input and a strobe control signal for each input channel. The signals can be programmed as active high or active low, edge or level based and can be controlled independently.

Serial Communication Ports

The X64-Analog features four independent onboard RS-232C ports that provide integrated support for camera control and setup for machine vision applications. PC-independent in nature, these communication ports can easily be used with off-the-shelf communication utilities such as Windows-based HyperTerminal.

Software Support

Image Acquisition and Control

The X64-An Quad is supported by Coreco Imaging's Sopera™ LT software libraries for image acquisition and control. Compatible with Microsoft Visual Studio 6.0 and .NET development environments, Sopera LT applications can be developed using C++ classes, C DLL or ActiveX controls under Windows® 2000, and Windows® XP platforms. An integral part of Coreco Imaging's stringent Trigger-to-Image Reliability technology framework, Sopera LT is hardware independent and supports Coreco Imaging's full range of imaging boards. In addition, the Sopera LT software includes powerful diagnostics and setup utilities for application development, custom camera configurations and system deployment.

Image Processing and Analysis

For image processing and analysis Coreco Imaging offers Sopera™ Processing. Sopera Processing software library is a set of high performance C++ classes specifically designed for machine vision applications. The Sopera Processing library includes over 300 image processing functions and high level image analysis tools for pattern matching, optical character recognition, bar code decoding and blob analysis.

Specifications*

Board	Full length 64-bit PCI-X 66MHz compatible Supports 5V and 3.3V slots
Acquisition	Concurrent image acquisition from four independent interlaced or progressive scan analog cameras Single slot solution supports acquisition rates up to 50MHz in 8-bit/pixel mode Horizontal Size (min/max): 32 pixels to 4096 pixels in 1 pixel/step Vertical Size: 1 to 16384 lines in 1 line/step Interfaces to monochrome standard or custom format cameras VBS 1 V _{pp} , 75 ohms terminated Video 0.714 V _{pp} , 75 ohms terminated Partial scan mode
Synchronization	Supports composite video and separate horizontal and vertical sync input Horizontal/Vertical Drive output, LV TTL and TTL compatible Frame reset and WEN inputs for each channel
Onboard memory Pixel Formats Transfers	128MB Onboard frame buffer memory Monochrome 8-bit/pixel Real-time transfers to system memory: PCI-32 bus: 32 bits @ 33MHz PCI-64 bus: 64 bits @ 66MHz PCI-X bus: 64 bits @ 66MHz
Pixel jitter	Robust error tracking, reporting and recovery
Look-up tables	One 256 x 8-bit look-up table per channel
Noise and Pixel Jitter	+/- 1 LSB with +/- 1.5ns jitter
Controls	Independent gain/offset control for each input channel from 0.4V to 1.2V 780µV/step Anti-aliasing filter: 12MHz ² 5th Butterworth Comprehensive event notification includes end/start-of-field/frame/transfer 4 independent opto-isolated trigger inputs; programmable as active high or low (edge or level trigger) 4 strobes TTL outputs PC independent RS232 serial communication ports provide seamless interface to MS Windows applications <i>Optional:</i> General purpose I/O modules supports 2 opto-isolated inputs, 2 TTL inputs, and 4 TTL outputs
Power Output	Power-on-reset fused +12V DC output at 750 mA(max) for each input channel
Software	Microsoft Windows XP and Windows 2000 compliant Full support of Coreco Imaging's Sopera programming package Microsoft Visual Studio 6.0 and .NET compatible C/C++ DLLs and ActiveX controls
System Requirements	PCI-X compliant system and 64MB system memory
Dimensions	12.25" (31cm) Length x 4.125" (10.5cm) Height
Temperature	0° C (32° F) to 55° C (131° F) Relative Humidity: up to 95% (non-condensing)
Markings	FCC – class B (pending) CE – class B (pending)

* Last updated October 2004

Notes:

1. Contact Coreco Sales for other cut off frequencies

CORECO
iMAGING

EXCELLENCE IN MACHINE VISION

7075 Place Robert-Joncas, Suite 142, St-Laurent, Quebec, Canada H4M 2Z2

Tel: 514.333.1301 US Subsidiary: 978-670-2000 Email: info@corecoimaging.com

visit us online @ www.imaging.com